



BIDS AND AWARDS COMMITTEE

Supplemental/Bid Bulletin No. 1

REPLACEMENT OF FIRE SPRINKLER SYSTEM AND INSTALLATION OF JOCKEY PUMP OF THE DEPARTMENT OF ENVIRONMENT AND NATURAL RESOURCES-CENTRAL OFFICE (DENR-CO)

Bid Ref. No. DENR-CO-2020-003 Rebid
(Previous IB No. DENR-CO-2019-010)

Approved Budget for the Contract: ₱ 25,000,000.00

This **Supplemental/Bid Bulletin No. 1** is being issued to revise provisions/specifications in the Bidding Documents, to address queries/clarifications raised by bidders during the pre-bid conference conducted on 14 February 2020 for the aforementioned project:

A. New Schedule of Bidding Activities

ACTIVITIES	DATE AND TIME	VENUE
1. Orientation for Bidders re conduct of Bidding Activities via Google Meet	03 August 2020, (Monday) 1:00 PM	Online via Google Meet Platform
2. Submission of Bid Documents	04 August 2020, (Tuesday) 10:00 AM	Main Lobby, DENR Main Building, Visayas Ave., Diliman, Quezon City
3. Opening of Bids	04 August 2020, (Tuesday) 10:30 AM	<ul style="list-style-type: none">Field Operations Conference Room, 5th floor, DENR Main Building, Visayas Ave., Diliman, Quezon City & via Google Meet PlatformOnline via Google Meet Platform

Note: Please refer to the Guidelines on the Conduct of Bidding Activities attached as Annex "A"

B. Revision to provisions/specifications in the Bidding Documents:

FROM

TO

Section III. Bid Data Sheet

12.1 (b)(ii.3)	The minimum work experience requirements for key personnel are the following:		
	Key Personnel	Description	Experience
	1.Sanitary Engineer	One registered and licensed Professional	At least five (5) years of experience related to the project
			Valid and current Professional Identification Card issued by Professional Regulation Commission

12.1 (b)(ii.3)	The minimum work experience requirements for key personnel are the following:		
	Key Personnel	Description	Experience
	1.Master Plumber	One registered and licensed Professional	At least five (5) years of experience related to the project
			Valid and current Professional Identification Card issued by Professional Regulation Commission

28	2 (a) 2018 Annual Income Tax Return and Latest Income Tax Returns per Revenue Regulations 3-2005; <i>Tax returns filed through the Electronic Filing and Payments System (EFPS). The latest income and business tax returns are those within the last six months preceding the date of bid submission (including copy of VAT returns and corresponding payments for the last 6 months):</i>
----	---

28	2 (a) 2019 Annual Income Tax Return and Latest Income Tax Returns per Revenue Regulations 3-2005; <i>Tax returns filed through the Electronic Filing and Payments System (EFPS). The latest income and business tax returns are those within the last six months preceding the date of bid submission (including copy of VAT returns and corresponding payments for the last 6 months):</i>
----	--

28 (3)(d)	3.d) List of contractor’s design and construction personnel with attached Certification of Availability, Curriculum Vitae and the following documentary requirements of Key Personnel per Annex VII:												
	<table border="1"> <thead> <tr> <th>No.</th> <th>Key Personnel</th> <th>Documentary Requirements</th> </tr> </thead> <tbody> <tr> <td>1.</td> <td>Sanitary Engineer</td> <td> <ul style="list-style-type: none"> Valid and current PRC ID Certification or equivalent document to prove five (5) years of experience. List of on-going projects </td> </tr> <tr> <td>2.</td> <td>Mechanical Engineer</td> <td> <ul style="list-style-type: none"> Valid and current PRC ID Certification or equivalent document to prove five (5) years of experience. List of on-going projects </td> </tr> <tr> <td>3.</td> <td>Welders/Pipe Fitters</td> <td> <ul style="list-style-type: none"> Valid and current PRC ID Certification or equivalent document to prove five (5) years of experience. List of on-going projects </td> </tr> </tbody> </table>	No.	Key Personnel	Documentary Requirements	1.	Sanitary Engineer	<ul style="list-style-type: none"> Valid and current PRC ID Certification or equivalent document to prove five (5) years of experience. List of on-going projects 	2.	Mechanical Engineer	<ul style="list-style-type: none"> Valid and current PRC ID Certification or equivalent document to prove five (5) years of experience. List of on-going projects 	3.	Welders/Pipe Fitters	<ul style="list-style-type: none"> Valid and current PRC ID Certification or equivalent document to prove five (5) years of experience. List of on-going projects
No.	Key Personnel	Documentary Requirements											
1.	Sanitary Engineer	<ul style="list-style-type: none"> Valid and current PRC ID Certification or equivalent document to prove five (5) years of experience. List of on-going projects 											
2.	Mechanical Engineer	<ul style="list-style-type: none"> Valid and current PRC ID Certification or equivalent document to prove five (5) years of experience. List of on-going projects 											
3.	Welders/Pipe Fitters	<ul style="list-style-type: none"> Valid and current PRC ID Certification or equivalent document to prove five (5) years of experience. List of on-going projects 											

28 (3)(d)	3.d) List of contractor’s design and construction personnel with attached Certification of Availability, Curriculum Vitae and the following documentary requirements of Key Personnel per Annex VII:												
	<table border="1"> <thead> <tr> <th>No.</th> <th>Key Personnel</th> <th>Documentary Requirements</th> </tr> </thead> <tbody> <tr> <td>1.</td> <td>Master Plumber</td> <td> <ul style="list-style-type: none"> Valid and current PRC ID Certification or equivalent document to prove five (5) years of experience. List of completed or on-going contracts of similar in nature </td> </tr> <tr> <td>2.</td> <td>Mechanical Engineer</td> <td> <ul style="list-style-type: none"> Valid and current PRC ID Certification or equivalent document to prove five (5) years of experience. List of completed or on-going contracts of similar in nature </td> </tr> <tr> <td>3.</td> <td>Welders/Pipe Fitters</td> <td> <ul style="list-style-type: none"> Valid and current PRC ID Certification or equivalent document to prove five (5) years of experience. List of completed or on-going contracts of similar in nature </td> </tr> </tbody> </table> <p>Note: Years of experience shall be counted from date of registration on PRC IDs for professionals and the date of issuance on certificates for others, or whichever is applicable.</p>	No.	Key Personnel	Documentary Requirements	1.	Master Plumber	<ul style="list-style-type: none"> Valid and current PRC ID Certification or equivalent document to prove five (5) years of experience. List of completed or on-going contracts of similar in nature 	2.	Mechanical Engineer	<ul style="list-style-type: none"> Valid and current PRC ID Certification or equivalent document to prove five (5) years of experience. List of completed or on-going contracts of similar in nature 	3.	Welders/Pipe Fitters	<ul style="list-style-type: none"> Valid and current PRC ID Certification or equivalent document to prove five (5) years of experience. List of completed or on-going contracts of similar in nature
No.	Key Personnel	Documentary Requirements											
1.	Master Plumber	<ul style="list-style-type: none"> Valid and current PRC ID Certification or equivalent document to prove five (5) years of experience. List of completed or on-going contracts of similar in nature 											
2.	Mechanical Engineer	<ul style="list-style-type: none"> Valid and current PRC ID Certification or equivalent document to prove five (5) years of experience. List of completed or on-going contracts of similar in nature 											
3.	Welders/Pipe Fitters	<ul style="list-style-type: none"> Valid and current PRC ID Certification or equivalent document to prove five (5) years of experience. List of completed or on-going contracts of similar in nature 											

28 (4)(b)	PCAB License with Classification/Category in General Building/General Engineering with License Category C or D and Size Range of Small B (SP-ME). The PCAB license must indicate "PCAB registered contractor for Government Projects."	28 (4)(b)	4.b) PCAB License with Classification/Category in General Building/General Engineering with License Category C or D, and Size Range of Small B both (SP-ME) and (SP-FP) . The PCAB license must indicate "PCAB registered contractor for Government Projects."
--------------	--	--------------	---

Section VI. Specifications

Terms of Reference	Terms of Reference (as of 25 June 2020)
3. Scope of Works	
3.23 Train eight (8) DENR personnel for the operation and maintenance of the fire sprinkler system and jockey pump;	3.23 Train ten (10) DENR personnel for the operation and maintenance of the fire sprinkler system and jockey pump;
4. Specifications of Works (4.3 Automatic Sprinkler and Standpipe System)	
4.3.16 The Contractor shall supply the following minimum tools for maintenance and other uses: <ul style="list-style-type: none"> ➤ 40 pcs of socket wrench set; ➤ 14 pcs of back wrench set; ➤ 14 pcs of open wrench set; ➤ 9 pcs of pipe wrench set with diameter of 200–610 mm; and ➤ 10 pcs of fire sprinkler stop valve. 	4.3.16 The Contractor shall supply the following minimum tools for maintenance and other uses: <ul style="list-style-type: none"> ➤ 1 set of pipe wrenches, from 6" to 20"; ➤ 1 set of back wrenches, from 1/2" to 24"; ➤ 1 set of socket wrenches, from 1/2" to 24"; ➤ 1 set of open wrenches, from 1/2" to 24"; and ➤ 14 pcs of fire sprinkler stop valve.
4. Specifications of Works (4.4 Identification Signs and Charts)	
<ul style="list-style-type: none"> ➤ The drain, alarm test valves, and other components shall have standard identification signs, painted fire red with white lettering. The signs shall be attached to the valve in a visible and noticeable position. 	<ul style="list-style-type: none"> ➤ The drain, alarm test valves, and other components, including piping, equipment materials, and devices, shall have standard identification signs and charts, such as but not limited to warning signs and labels, pipe labels, valve tags, warning tags, and stencil. The standard shall be A13.1, also titled Scheme for the Identification of Piping Systems, by the American Society of Mechanical Engineers. The lettering shall be in fire red with white. The signs and charts shall be attached to a visible and noticeable position.
5. General Requirement	
<ul style="list-style-type: none"> ➤ <i>None</i> 	<ul style="list-style-type: none"> ➤ The Contractor shall submit an emergency evacuation safety plan, including meeting point area, for the Department in case of emergency.
<ul style="list-style-type: none"> ➤ <i>None</i> 	<ul style="list-style-type: none"> ➤ The Contractor shall strictly follow the guidelines on the fight against COVID-19 issued by the Inter-Agency Task Force, DPWH (specifically Department Order No. 35, Series of 2020), local government, as well as other offices, agencies, and departments of the Philippines.

12. Guarantee

➤ *None*

➤ The contractor shall furnish a written guarantee covering the satisfactory operation of the project in repair, replacement of defective items for a period of 2 years, and availability of spare parts for at least 10 years after the issuance of Certificate of Acceptance.

Bidders are advised to use the attached **Terms of Reference as of 25 June 2020 with Working Drawings** together with all other required documents for the submission of bids on **04 August 2020, 10:00 AM**.

Please use the **Revised Checklist of Requirements** as a guide/reference.

This Supplemental/Bid Bulletin No. 1 shall form part of the Bidding Documents. Any provision in the Bidding Documents inconsistent herewith is hereby amended, modified and superseded accordingly.

For guidance and information of all concerned.

Issued this 21st day of July 2020 in Quezon City.

Approved by:

MARCIAL C. AMARO, JR., CESO III
Assistant Secretary for Policy, Planning and Foreign Assisted and Special Projects & Chairperson, Bids and Awards Committee

Received by:	
_____ (SIGNATURE OVER PRINTED NAME & DATE)	_____ NAME OF COMPANY
(PLEASE RETURN OR FAX THIS PAGE ONLY TO THE DENR BAC OFFICE @ 8926-2675)	

GUIDELINES ON THE CONDUCT OF BIDDING ACTIVITIES

The exceptional circumstances brought about by COVID 19 pandemic enjoined the Department to maximize the use of existing rules under the Republic Act (RA) No. 9184, its Implementing Rules and Regulations (IRR) and related issuances to streamline, simplify and expedite the conduct of procurement to ensure continuous delivery of public services.

Pursuant to Government Procurement Policy Board (GPPB) Resolution No. 09-2020 dated 07 May 2020, allowing the procuring entity to use videoconferencing, webcasting and similar technology in the conduct of any of the meetings, all prospective bidders are advised to follow the set guidelines enumerated below:

A. Conduct of Pre-bid Conference

- 1) The conduct of Pre-bid Conference shall be thru videoconferencing using Google Meet platform. To ensure familiarity of prospective bidders, an orientation will be conducted online at 1:00 PM a day before the scheduled Pre-bid Conference. Please be guided by the following:
 - a) Prospective bidders are required to install the Google Meet Application downloadable at Google Play Store for Android users and at App Store for IOS/Apple users.
 - b) Prospective bidders are advised to submit to the BAC Secretariat at **bac.co@denr.gov.ph** their contact details as well as their email addresses to be used for the videoconferencing at least one (1) day before the date of orientation.
 - c) Only one (1) representative with his/her email address per company shall have an access in the videoconference proceedings.
 - d) The representative who attended the Orientation shall be the same representative to attend on the Pre-bid Conference. This shall also apply to the email address being submitted and used during the Orientation.
 - e) A Google Meet link shall be sent by the BAC Secretariat as an invitation to the email addresses provided by the prospective bidders at least thirty (30) minutes before the schedule of Orientation and at least twenty (20) minutes before the schedule of Pre-bid Conference.
 - f) Representatives are not allowed to share in any manner the provided Google Meet link.
 - g) Prospective bidders who were not able to submit their email addresses in advance may still join the videoconferencing by sending an email to the BAC Secretariat with their contact details and email addresses at least twenty (20) minutes before the schedule of Pre-bid Conference, provided however that the former shall be responsible in ensuring all requirements needed to successfully join to Google Meet thru the link to be provided by the BAC Secretariat considering that Orientation has not been attended.
- 2) Representatives are advised to be on standby at least fifteen (15) minutes before the start of the Pre-bid Conference to check if connection is successful. Failure to do so shall be marked as late restricting the bidder to question any activities that were conducted in his/her absence.

- 3) Prospective bidders are encouraged to secure a copy of the Bidding Documents downloadable at the DENR and PhilGEPS websites. Prospective bidders are expected to have judiciously read and understood said documents and the project's requirements prior the schedule of Pre-bid Conference.
- 4) During the Pre-bid Conference, prospective bidders are advised to turn on the Video of the device being used and are requested to state their complete name and the company being represented, respectively, during the roll call, for recording and attendance purposes.
- 5) Queries/clarifications will be done per prospective bidder, for a well-organized conduct of the Pre-bid Conference.

B. Submission of Bidding Documents

- 1) The submission of bidding documents shall be thru physical submission at the lobby of the Main Building of the DENR-CO, to be received by a BAC Secretariat Personnel.
- 2) For safety precautions, bidders are required to wrap/cover their respective bidding documents with clear plastic to facilitate disinfection and evaluation on the proper sealing and marking of bid envelopes pursuant to Section 25.9 of the 2016 Revised IRR of RA No. 9184 which states that unsealed or unmarked bid envelopes shall be rejected.
- 3) Participating bidders may send in advance queries/clarifications on the submission of bidding documents at the BAC Secretariat thru email at **bac.co@denr.gov.ph** or thru phone call at **[\(+632\) 8926-26-75](tel:+63289262675)**.

C. Opening of Bids

- 1) The opening of bids shall be conducted on its scheduled date and time thru videoconferencing using Google Meet platform. To ensure familiarity of participating bidders, an orientation will be conducted online at 1:00 PM a day before the scheduled Opening of Bids. Please be guided by the following:
 - a) Participating bidders are required to install the Google Meet Application downloadable at Google Play Store for Android users and at App Store for IOS/Apple users.
 - b) Participating bidders are advised to submit to the BAC Secretariat at **bac.co@denr.gov.ph** their contact details as well as their email addresses to be used for the videoconferencing at least one (1) day before the date of orientation.
 - c) Only one (1) representative with his/her email address per company shall have an access in the videoconference proceedings.
 - d) The representative who attended the Orientation shall be the same representative to attend on the Opening of Bids. This shall also apply to the email address being submitted and used during the Orientation.

- e) A Google Meet link shall be sent by the BAC Secretariat as an invitation to the email addresses provided by the participating bidders at least thirty (30) minutes before the schedule of Orientation and at least twenty (20) minutes before the schedule of Opening of Bids.
 - f) Representatives are not allowed to share in any manner the provided Google Meet link.
- 2) Representatives are advised to be on standby at least fifteen (15) minutes before the start of the Opening of Bids to check if connection is successful. Failure to do so shall be marked as late restricting the bidder to question any activities that were conducted in his/her absence.
 - 3) Once there is a quorum, the presiding officer shall proceed with the roll call to record the attendance of the participating bidders and the company they represent respectively.
 - 4) Thereafter, upon the instruction of the presiding officer, the BAC Secretariat shall officially announce the start of the opening of bids.

D. Important Reminders

- 1) The DENR-CO does not issue Certification or equivalent document on the conduct of Conferences and/or Submission and Opening of Bids for Checkpoint clearance purposes. Prospective and participating bidders are advised to print Invitation to Bid, Notices/Advisories and/or Bid Bulletin/s issued by the DENR-CO showing the schedule of activities.
- 2) Queries/clarifications, if any, pertaining to this advisory may be sent in advance to the BAC Secretariat thru email at bac.co@denr.gov.ph or thru phone call at **(+632) 8926-26-75**, to be addressed and responded accordingly.

For information and guidance.

DIANNE G. IBIAS
OIC Chief, Procurement Management Section &
Head, BAC Secretariat

ELIZAR S. CANTUBA
Chief, Network Infrastructure and Management Division &
Member, BAC

Approved by:

MARCIAL C. AMARO, JR., CESO III
Assistant Secretary for Policy, Planning and Foreign Assisted and Special Projects &
Chairperson, Bids and Awards Committee

Instruction to Bidders: Please fill up the form accordingly and sign the Bidder's Undertaking. Failure to conform will result in a rating of "FAILED".

I. REVISED TERMS OF REFERENCE AS OF 25 JUNE 2020

**TERMS OF REFERENCE
REPLACEMENT OF FIRE SPRINKLER SYSTEM
AND INSTALLATION OF JOCKEY PUMP
(DENR Compound, Visayas Avenue, Diliman, Quezon City)**

1. INTRODUCTION

Title of the Project : **Replacement of Fire Sprinkler System and Installation of Jockey Pump**

Project Location : **DENR Main Building,
DENR Compound, Visayas
Avenue, Diliman, Quezon City**

Approved Budget for the Contract (ABC) : **P 25,000,000.00**

Construction Period : **180 Calendar Days**

2. OBJECTIVES

- 2.1 To provide the prospective contractors with sufficient background information on the **Replacement of Fire Sprinkler System and Installation of Jockey Pump at DENR Main Building, DENR Compound, Visayas Avenue, Diliman, Quezon City**, which will be completed within the shortest time possible at a cost most advantageous to the government in an acceptable quality and workmanship;
- 2.2 To describe the proposed project and its objectives, including Scope of Works and Deliverables, in detail; and
- 2.3 To determine the roles and responsibilities of the winning contractor during and after the construction period.

3. SCOPE OF WORKS

- 3.1 The Contractor, at its own expense, shall supply the necessary documents to satisfactorily complete the Installation and Replacement of Fire Sprinkler System and Jockey Pump at the Department of Environment and Natural Resources (DENR) compound in accordance with the Plans, Specifications, and Scope of Services approved by DENR's representative: Demolition Permit, Building Permits, Structural Design Analysis and Computation of Loads, Working Drawings, As-built Plans, Labor, Materials, Transportation, Tools, Supplies, Equipment, Appurtenances, including Management and Supervision of the Project;
- 3.2 The Contractor shall furnish all materials, equipment, tools, labor and services necessary for the complete Installation and Replacement of Fire Sprinkler System and

E.T.SA

1

**TOR for the Replacement of Fire Sprinkler System and Installation of Jockey Pump
(DENR Compound, Visayas Avenue, Diliman, Quezon City)**

Jockey Pump in strict accordance with the technical specifications and drawings, complete and ready for use.

- 3.3 The Contractor shall conduct site inspection to determine the specific needs of the project; and
- 3.4 The Contractor shall perform the following tasks at par with acceptable standards:

- 3.3.1. Arrange or obtain and the cost of necessary permits, bonds and fees for the automatic sprinkler work;
- 3.3.2. Pay all permit fees;
- 3.3.3. Supply and install sprinkler system for the floors shown on the plans;
- 3.3.4. Submit detailed shop drawings for review and approval of DENR, where the system shall include all pipes, hangers, sway braces, and control valve monitor switches;
- 3.3.5. Supply and install fire pumps and jockey pump, including controllers and pumps accessories;
- 3.3.6. Supply and install all electrical power connections, including electrical power connection to emergency power;
- 3.3.7. Supply and install fire hose cabinets, including all accessories: fire hose 1 ½ x 50 ft, male and female brass coupling, 1-1/2 angle valve, 1-1/2 brass nipple, straight nozzle, and semi-automatic hose rack;
- 3.3.8. Supply and install alarm check valves, complete with set of trimmings, retarding chamber, water motor alarm gong, and alarm pressure switches;
- 3.3.9. Coordinate and interface the required electrical wiring connections to the Building Central Fire Alarm System;
- 3.3.10. Supply and install dry standpipe system, complete with valves and fire department connection as shown in the plans;
- 3.3.11. Furnish and install fire department connection for wet sprinkler system;
- 3.3.12. Furnish and install inspector's test connection pipe, sight glass, and valves on the farthest point of each floor as shown in the plans;
- 3.3.13. Supply and install floor control valve, including water flow switch, supervisory switch, and pressure gauges on each floor as shown in the plans;
- 3.3.14. Furnish and install the conduit and wiring connection of the water flow switch and supervisory switch to sprinkler monitoring control panel and interfaced to the Building Fire Alarm Panel;
- 3.3.15. Conduct testing of all piping works and necessary cleaning of the fire protection works including testing of the fire department pipeline (dry pipe) and drain pipe and sprinkler monitor alarm panel;
- 3.3.16. Seal all openings through which fire may spread from the pipe with fire-resistant materials;
- 3.3.17. Conduct chipping and plastering works necessary for the area covered in the installation of automatic sprinkler system;
- 3.3.18. Furnish the DENR with shop drawings and secure certificate of inspection;
- 3.3.19. Remove all rubbish and debris resulting from the fire protection work periodically from the jobsite;
- 3.3.20. Pipe and install new water supply for cistern tank tapped to nearest MWSS supply line;

E.T.SA

2

**TOR for the Replacement of Fire Sprinkler System and Installation of Jockey Pump
(DENR Compound, Visayas Avenue, Diliman, Quezon City)**

- 3.3.21. Provide project schedule in Gantt chart and PERT/CPM; and
- 3.3.22. Remove existing fire sprinkler system;
- 3.3.23. Train 10 DENR personnel for the operation and maintenance of the fire sprinkler system and jockey pump;
- 3.3.24. Provide back up as necessary for the operation and maintenance of the fire sprinkler system and jockey pump, wherein the service response time is within 24 hours.

4. SPECIFICATIONS OF WORKS

4.1. SHOP DRAWINGS AND DATA

- 4.1.1. Before commencing any work or providing any materials at the jobsite for this project, the Contractor shall submit for approval to the Director of Administrative Service four (4) copies of catalog cuts and descriptive matter regarding materials and equipment intended to furnish and install.
- 4.1.2. Shop drawings and data shall be submitted specifically for, but not limited to the following items: Sprinkler heads, valves, pipe hangers, hose valve and accessories, fire department connections, fire pumps and jockey pumps, controllers, fire hose cabinets, mechanical grooved coupling (flexible pipe connectors), pressure reducing valves, pipe riser support and sleeves, portable fire extinguishers, and other equipment.
- 4.1.3. The Contractor shall not proceed with the installation of the work until he has received the approval of the Director of Administrative Service on shop drawings.
- 4.1.4. The approval of shop drawings, catalogue cuts, and other documents shall not relieve the Contractor of the responsibility of any errors or omissions which may exist in the items submitted nor shall relieve from the responsibility of deviations from the contract drawings and specifications.
- 4.1.5. The stamped approval of the shop drawings, catalogue cuts, and other documents shall not be construed as a complete check but will indicate only that the general design and method of construction is satisfactory.

4.2. SELECTION OF MATERIALS AND EQUIPMENT

- 4.2.1. All materials are brand new and all equipment furnished under this section (15500) shall be approved by Underwriter's Laboratories, Inc. (UL) and Factory Mutual (FM) or equivalent.
- 4.2.2. The proposal submitted shall include all materials and equipment as specified or shown on the drawings.

4.3. AUTOMATIC SPRINKLER AND STANDPIPE SYSTEM

- 4.3.1. The Contractor shall furnish automatic sprinkler as follows:
 - Brand new;
 - Designed for 175 psi working pressure;
 - Conforming to ASTM specifications; and
 - Has the name or brand along with the applicable ASTM Standard, marked on each length of pipe.
- 4.3.2. The Contractor shall furnish sprinkler piping as follows:
 - Schedule 40 black iron;

E.T.SA

3

**TOR for the Replacement of Fire Sprinkler System and Installation of Jockey Pump
(DENR Compound, Visayas Avenue, Diliman, Quezon City)**

- In accordance to ASTM A120 or A53;
 - Joined by screwed joints in accordance with specifications ANSI B18.2 1"Ø up to 2"Ø and flanged or groove type connections for 2-1/2"Ø and up, where pipe fittings to be used with schedule 40 pipes shall be rated 300 lbs. class;
 - Sprinkler piping that is exposed to the weather or used in a corrosive atmosphere shall be painted with protective coating;
 - Sprinkler piping in the building shall be painted with two coats of enamel primer and two coats of Fire Red color enamel paint; and
 - All ASTM A53 and ASTM A120 sprinkler pipe must be hydrostatically tested at the mill per the ASTM Standard (Certification from the Manufacturer).
- 4.3.3. The Contractor shall furnish screwed fittings as follows:
- Shall be malleable iron;
 - 300 lbs and 150 lbs class;
 - Black; and
 - In accordance with ANSI B16.3.
- 4.3.4. The Contractor shall furnish flange fittings as follows:
- Shall be steel;
 - Short body;
 - 150 lbs class;
 - Black;
 - In accordance with ANSI B16.1;
 - Gaskets shall be full face of 1/8" minimum thickness red sheet rubber;
 - Flanged bolts and heavy semi-finished hexagon head nuts, cadmium plated, having dimension in accordance with ANSI B18.2.
- 4.3.5. The Contractor shall furnish weld fittings as follows:
- Shall be steel;
 - Standard Weight;
 - Black; and
 - In accordance with ANSI B16.25, ASTM B16.5 of ANSI B16.11.
- 4.3.6. The Contractor shall furnish outside screw and yoke gate valves as follows:
- Shall be flanged;
 - Iron body;
 - Bronze mounted;
 - 175 psi working pressure;
 - With hand wheel turning counter clockwise to open; and
 - Shall be UL/FM tested.
- 4.3.7. The Contractor shall furnish valve for main riser as follows:
- Shall gate valve or globe type;
 - Bronze body;
 - Screwed;
 - 175 psi pressure rating;
 - 6 in size; and

E.T.SA

4

TOR for the Replacement of Fire Sprinkler System and Installation of Jockey Pump
(DENR Compound, Visayas Avenue, Diliman, Quezon City)

- Renewable composition soft disc.
- 4.3.8. The Contractor shall furnish valve for auxiliary drain and inspector's test connection as follows:
- Shall globe type;
 - Bronze body;
 - Screwed;
 - 175 psi pressure rating;
 - 2 in size; and
 - Renewable composition disc.
- 4.3.9. At each location where called for on plans or where required by the Fire Department, provide an approved retard-type electric flow alarm switch. Provide alarm bell as required. Flow alarm switch shall have extra set of contacts for extension by other to central alarm panel.
- 4.3.10. The Contractor shall furnish flow switch as follows:
- Shall be vane type;
 - 24 volts; and
 - Shall be tested and listed by UL and or FM.
- 4.3.11. The Contractor shall furnish OS&Y Gate Valve Supervisory Switch as follows:
- 24 volts; and
 - Shall be tested and listed by UL and/ or FM.
- 4.3.12. The Contractor shall furnish fire hose cabinet as follows:
- Shall be recessed;
 - Gauge 16 steel body;
 - Aluminum door trim;
 - Designed to fit 50ft hose pi rack and fire extinguisher;
 - Door shall be full panel glass;
 - Furnish and install one (1) each – 4.5kgs (10lbs) Capability ABC Cry powder chemical, multipurpose type portable fire extinguisher with attached MSDS (EMS Compliant); and
 - Provide fire axe to be placed inside the cabinet.
- 4.3.13. The Contractor shall furnish pin rack for fire hose cabinet as follows:
- Shall be semi-automatic type;
 - baked red enamel finish;
 - Designed for 50ft of 1-1/2" hose; and
 - Furnished with 1-1/2" chrome plated brass rack nipple.
- 4.3.14. The Contractor shall furnish fire hose as follows:
- Shall be 50 feet of 1-1/2" cotton single jacket;
 - Rubber lined hose with wax and gum treatment;
 - 1-1/2" chrome plated coupling;
 - Male-female national standard hose threads; and
 - Shall be approved by UL and or FM.
- 4.3.15. The Contractor shall furnish nozzle for fire hose as follows:
- Shall be 1-1/2" adjustable;
 - Capable of complete shut-off;

E.T.SA

5

**TOR for the Replacement of Fire Sprinkler System and Installation of Jockey Pump
(DENR Compound, Visayas Avenue, Diliman, Quezon City)**

- Solid straight stream or any degree of solid conical fog;
- Chrome plated;
- Threads shall be national standard hose threads; and
- Shall be approved by UL and or FM.

4.3.16. The Contractor shall supply the following minimum tools for maintenance and other uses:

- 1 set of pipe wrenches, from 6" to 20";
- 1 set of back wrenches, from 1/2" to 24";
- 1 set of socket wrenches, from 1/2" to 24";
- 1 set of open wrenches, from 1/2" to 24"; and
- 14 pcs of fire sprinkler stop valve.

4.4. IDENTIFICATION SIGNS AND CHARTS

4.4.1. The drain, alarm test valves, and other components, including piping, equipment materials, and devices, shall have standard identification signs and charts, such as but not limited to warning signs and labels, pipe labels, valve tags, warning tags, and stencil. The standard shall be A13.1, also titled Scheme for the Identification of Piping Systems, by the American Society of Mechanical Engineers. The lettering shall be in fire red with white. The signs and charts shall be attached to a visible and noticeable position.

4.5. SPRINKLER HEADS

4.5.1. The Contractor shall furnish sprinkler heads as follows:

- Shall be recessed, upright, pendent, vertical side wall, horizontal side wall type as required;
- 12mm dia. and/or 13.5mm dia.;
- Pipe threads, rated at 68 degrees Centigrade, 93 degrees C, and/ or 121 °C;
- Sprinklers in areas with suspended ceiling the escutcheon plates shall be of the same finish as the textures of the ceiling boards;
- Shall be 93 °C at the parking area with orifice and glass bulb upright type, brass finish and with a K-factor of 5.6;
- Shall be 68 °C. at the office areas with standard orifice glass bulb quick response recessed type, chrome finish with a K-factor of 5.6; and
- Shall be tested and listed by UL and/ or FM.

4.5.2. The Contractor shall furnish a steel enameled box housing for the spare sprinkler heads and a sprinkler wrench as shown on the plan.

4.6. FIRE PUMP

4.6.1. The fire pump assembly shall be supplied and to be installed by the Contractor as follows:

- Furnish and install the pumps at the basement of the building;

E.T.SA

6

**TOR for the Replacement of Fire Sprinkler System and Installation of Jockey Pump
(DENR Compound, Visayas Avenue, Diliman, Quezon City)**

- All pumps shall be complete with motor, motor starter, control, fittings, and other appurtenances and accessories necessary to complete the equipment installation; and
- Pump shall be connected as shown in the drawings. Complete installation shall be in accordance with the requirements and in compliance with NFPA 20, Philippine Insurance Rating Association (PIRA) and of the Fire Department.

4.7. EXECUTION AND PROTECTION OF WORKS

- 4.7.1. The interior surfaces of all piping and equipment shall be clean and free of all dirt, loose scale, rust, and other foreign materials before installation.
- 4.7.2. Pipe ends shall be reamed to remove all burrs and pipe sections shall be cleaned inside to remove all chips and foreign material prior to making up joints.
- 4.7.3. Approved joint compound shall be applied to the threads of the pipe and not in the fittings when making up joints. Pipes shall not extend into the waterways of the fitting.
- 4.7.4. Sprinkler heads installed where they may be exposed or subjected to mechanical damage shall be furnished complete with head guards.
- 4.7.5. When welding pipe on jobsite, the fire hazard of the welding process shall have suitable safeguards. Additional personnel shall monitor all welding activities, with a fire extinguisher on hand. Weld in place of pipe and fittings shall not be allowed at the jobsite. Only shop weld fabrication will be permitted with factory made fittings. Mitered weld will not be provided with flanged or grooved type fittings.
- 4.7.6. Pipe passing through the building walls and floors above grade shall be provided with sleeves of standard weight galvanized steel pipe. The annular spaces between pipes and sleeves shall be packed tight insulated fire resistive materials. Provide chrome plated escutcheon plated large enough to cover the pipe sleeves. Sleeves shall be sized as follows:

SIZE OF PIPE		SIZE OF ID SLEEVE	
1 in	25 mm	2 in	50 mm
1-1/4 in	32 mm	2 in	50 mm
1-1/2 in	40 mm	2-1/2 in	65 mm
2 in	50 mm	3 in	75 mm
2-1/2 in	65 mm	4 in	100 mm
3 in	75 mm	5 in	125 mm
4 in	100 mm	6 in	150 mm
6 in	150 mm	8 in	200 mm
8 in	200 mm	10 in	250 mm

4.8. PIPE SUPPORTS

- 4.8.1. All piping shall be supported by means of hangers of approved quality, capable of supporting load. Sizing, spacing and installation shall be in accordance with National Fire Protection Association Standard No. 13, "Sprinkler Systems."
- 4.8.2. Fire Protection Contractor shall furnish and install the required sprinkler pipe seismic sway bracing for the risers, feed main-pipe and cross-main pipe all in

E.T.SA

**TOR for the Replacement of Fire Sprinkler System and Installation of Jockey Pump
(DENR Compound, Visayas Avenue, Diliman, Quezon City)**

accordance with the tables and figures shown on NFPA-13 requirements for the protection of the piping against breakage due to Seismic Earthquake movement.

4.8.3. No cutting, drilling, welding or burning of a structural steel member of the DENR Main Building shall be allowed. Power driven studs and welding shall not be allowed.

4.8.4. All bolts and threaded rods shall be used with double nut and washer wherever a supported piping to drop.

4.9. TEST AND INSPECTION

4.9.1. The Contractor shall conduct and bear the costs of all necessary tests of the fire protection work, furnishing all labor, power and equipment. All piping shall be tested with water and test witnessed by representatives of the DENR Project Management Team.

4.9.2. The fire protection piping shall be tested per floor under a hydrostatic pressure of not less than 200psi, for duration of 24 hours at 50lbs per square inch more than the maximum static pressure when the maximum pressure is in excess of 150lbs per sq. in.

4.9.3. The piping subjected to the hydrostatic test shall be proven tight or acceptable by the test. Defective work or materials shall be corrected or replaced. If necessary, piping shall be dismantled and reassembled with the use of new pipes or fittings as no caulking or make shift method of temporary repair of defective work will be permitted. Test shall be repeated until the particular line or system receives the approval of the owner.

4.9.4. Acceptance of the automatic sprinkler work shall be used upon inspection and tests of the completed installation by the representatives of the local Fire Department and DENR Project Management Team.

4.9.5. Before the project is turned-over, the Contractor shall provide copies (digital and hard copies) of the as-built plans. The Contractor shall also furnish the "Contractor Material Test Certificate" in the NFPA – 13 forms and the "Fire Pumps Acceptance Test" as per NFPA – 20 fire code, duly signed by authorized person concerned. These forms are to be submitted to the Insurance Company.

4.9.6. The required Certificate of Occupancy shall be obtained by the Contractor from the Quezon City Local Government.

5. GENERAL REQUIREMENT

5.1 The Contractor shall supply and submit a list of manpower, materials, and equipment necessary for the project in accordance with the approved Specifications, Plans, and Scope of Works.

5.2 The Contractor shall prepare and submit As-Built Plans.

5.3 The Contractor shall submit an emergency evacuation safety plan, including meeting point area, for the Department in case of emergency.

5.4 The Contractor shall comply with pertinent regulations and adopt safety measures, such as but not limited to: enclosures, shielding, coverings, warning devices, off limits signs, etcetera.

5.5 The Contractor shall submit pictures taken before the construction.

E.T.SA

8

**TOR for the Replacement of Fire Sprinkler System and Installation of Jockey Pump
(DENR Compound, Visayas Avenue, Diliman, Quezon City)**

- 5.6 The Contractor shall submit monthly Accomplishment Report accompanied with pictures every first Monday of the succeeding month, addressed to the Director of Administrative Service.
- 5.7 The Contractor shall submit pictures taken before the construction.
- 5.8 The Contractor shall have visited the site and thoroughly inspect existing facilities and considered, in the preparation of his tender, how such conditions will affect the work required by the drawings and specifications, and failure to do so will in no way relieve the Contractor of the responsibility for furnishing labor, materials, and equipment required.
- 5.9 The Contractor shall not claim additional payments or damages for any delay or extra expense caused by encountering construction or materials other than anticipated or different from those indicated.
- 5.10 The Contractor shall assume full responsibility for any and all damages to the existing construction and to verify facilities.
- 5.11 The Contractor shall take any necessary photographs of existing conditions and shall file a report with the Implementing Agency, listing any existing damaged construction before the work is started.
- 5.12 The Contractor shall finish the construction with first class workmanship to the satisfaction of the DENR Management.
- 5.13 The Contractor shall only use materials in accordance to the standards of the Bureau of Research and Standards of the Department of Public Works and Highways, the Department of Science and Technology, or the Department of Trade and Industry.
- 5.14 The Contractor shall conform with the Environment Management System being practiced by the DENR Central Office in accordance with ISO 14001-2015 by providing the following:
 - 5.14.1 A List of pre-identified Environmental Aspects and Impacts and the corresponding operational control or crisis response procedures in cases of emergency situations shall be submitted to the GSD three days upon receipt of the NTP;
 - 5.14.2 All supplies and materials to be brought inside the DENR premises shall be green labelled or environment friendly (if applicable) and bear the corresponding Material Safety Data Sheet (MSDS);
 - 5.14.3 All hazardous materials necessary for the completion of the project shall be properly labelled with MSDS and placed in a secondary containment and located at the safest place in the working area; and
 - 5.14.4 All hazardous wastes generated shall be properly turned over to DENR MRF for the inventory and subsequent disposition enlisting the services of authorized treater/transporter.
- 5.15 The Contractor shall adopt a procedure to mitigate the effects to the environment of demolition, repair, painting and other activities.
- 5.16 The Contractor shall ensure that all staff are wearing their working apparels with IDs and provided with necessary safety gears.
- 5.17 The Contractor shall strictly enforce the NO STYRO OR PLASTIC POLICY in the working area.
- 5.18 The Contractor shall train DENR personnel assigned by the Director of Administrative Service for the operation and maintenance of the fire sprinkler system.

E.T.SA

9

**TOR for the Replacement of Fire Sprinkler System and Installation of Jockey Pump
(DENR Compound, Visayas Avenue, Diliman, Quezon City)**

- 5.19 The Contractor shall strictly follow the guidelines on the fight against COVID-19 issued by the Inter-Agency Task Force, DPWH (specifically Department Order No. 35, Series of 2020), local government, as well as other offices, agencies, and departments of the Philippines.

6. MANPOWER AND EQUIPMENT REQUIREMENT

- 6.1 The Contractor shall have a current and valid Philippine Contractors Accreditation Board License of at least Small B for Fire Protection Works and Mechanical Works.
- 6.2 The Contractor must be operating for at least five (5) years.
- 6.3 The Contractor shall at least provide four welders/pipefitters, who must be NC-II certified by the Technical Education and Skills Development Authority. These welders/pipefitters must have at least five (5) years of experience.
- 6.4 The Contractor shall provide a professional licensed and registered mechanical engineer, who has at least five (5) years of experience related to the project.
- 6.5 The Contractor shall provide a licensed and registered master plumber, who has at least five (5) years of experience related to the project.
- 6.6 The Contractor shall provide at least one of each following equipment:
- 6.6.1 Pipe threader machine
 - 6.6.2 Inverter-type welding machine with 300 amp
 - 6.6.3 Heavy-duty pipe wrench
 - 6.6.4 Heavy-duty cutting machine
 - 6.6.5 Heavy-duty electrical drill
 - 6.6.6 Heavy-duty grinder
 - 6.6.7 Service vehicle/dump truck
 - 6.6.8 Heavy-duty socket wrench set
 - 6.6.9 Heavy-duty buck wrench set
- 6.7 The Contractor shall submit the following:
- 6.7.1 Curriculum Vitae of the abovementioned personnel;
 - 6.7.2 Copy of valid and current certificates and cards issued by respective agencies of the abovementioned professionals; and
 - 6.7.3 List of completed or on-going contracts of similar in nature.

7. APPROVED BUDGET FOR THE CONTRACT

- 7.1 The estimated cost of this construction is Twenty-Five Million Pesos (Php 25,000,000.00) inclusive of all applicable government taxes and charges.

8. CONTRACT FEE AND MODE OF PAYMENT

- 8.1 In consideration of the services to be performed under this TOR, the DENR shall pay the Contractor the contract amount inclusive of all applicable taxes.

E.T.SA

10

**TOR for the Replacement of Fire Sprinkler System and Installation of Jockey Pump
(DENR Compound, Visayas Avenue, Diliman, Quezon City)**

- 8.2 DENR may, upon written request by the Contractor, make and advance payment not exceeding fifteen percent (15%) of the Contract Amount upon submission of an irrevocable letter of credit or bank guarantee issued by a Universal or Commercial Bank. This will cover expenses for mobilization and construction start-up.
- 8.3 Advance payment of the contract amount shall also be allowed for procurement of goods required to address contingencies arising from natural or man-made calamities in areas where a "State of Calamity" has been by appropriate authorities.
- 8.4 Upon submission of an irrevocable letter of credit or bank guarantee issued by a Universal or Commercial Bank, the advance payment shall be allowed and paid within sixty (60) calendar days from signing of the contract. The irrevocable letter of credit or bank guarantee must be for an equivalent amount, shall remain valid until the goods are delivered, and accompanied by a claim for the advance payment.
- 8.5 Mode of Payment will be through progress billing. Actual work accomplishment will be verified and approved by the Director of Administrative Service.

Description	Deliverables	Percentage of Contracted Amount
Mobilization	Approved Contract and Clearances	15%
Progress Billing No. 1	Gantt Chart and PERT/CPM detailing that 30% of the Progress Billing is accomplished	15%
Progress Billing No. 2	Gantt Chart and PERT/CPM detailing that 55% of the Progress Billing is accomplished	25%
Progress Billing No. 3	Gantt Chart and PERT/CPM detailing that 70% of the Progress Billing is accomplished	25%
Final Billing	Final Report, Approval of the Director of Administrative Service, and Certificate of Completion and Acceptance	20%

9. SUB-CONTRACTING

- 9.1 The Contractor shall not sub-contract the performance of the SERVICES stipulated in this TOR subjects of this Agreement or any part thereof without the written consent of the DENR.

10. MISCELLANEOUS PROVISION

- 10.1 The Contractor shall hold the DENR free from any and all claims, liabilities, losses and suits arising from the Contractor's services, or the acts, omissions or conduct of all persons employed or allowed by the Contractor or participate or assists in the performance of its obligations under this TOR.

E.T.SA

10.2 However, the DENR shall have the right to declare this Agreement rescinded and terminated after due notice upon failure of the Contractor to comply with any terms and conditions of this Agreement without prejudice to such other rights of the DENR to proceed against the Contractor as may be warranted by the circumstances, including forfeiture or performance bond and/or the filing of appropriate administrative, civil/or criminal charges against the responsible persons.

10.3 Any extension of the contract duration shall not involve any additional cost to the DENR.

10.4 The Contractor shall comply with all existing laws, decrees, ordinances, acts and regulations of the Philippines which may affect the contract in any way, including the express and implied warranties and liabilities which may be found therein.

10.5 The Contractor shall comply with all existing laws and pertinent social legislation, executive and administrative orders, together with all implementing rules and regulations issued by the Department of Labor and Employment (DOLE) and other relevant governmental authorities.

11. VIOLATION OF THE CONTRACT

11.1 If the Contractor shall violate any if the terms and conditions of this TOR, or shall neglect to perform any of their work, duties functions, responsibilities or obligations stipulated herein, or for any other causes shall not carry the tasks in acceptable manner, and by the reason thereof, the DENR suffers damages or losses, the Contractor shall be assessed a penalty in the form of liquidated damages in the amount of at least equal to one-tenth of one percent (1/10 of 1%) of the cost of the unperformed portion for everyday of delay.

12. GUARANTEE

12.1 The contractor shall furnish a written guarantee covering the satisfactory operation of the project in repair, replacement of defective items for a period of 2 years, and availability of spare parts for at least 10 years after the issuance of Certificate of Acceptance.

Prepared and Submitted by:

(sgd) **AR. KATRINA CARLA I. CATAPANG**
OIC-Chief, GSD-BGMS

Checked by:

(sgd) **ENGR. JAIME F. JACOBO**
OIC Asst. Chief, GSD

Noted by:

(sgd) **ENGR. GUILLERMO V. ESTIPONA, JR.**
OIC-Chief, GSD

Concurred:

(sgd) **RABINDRANATH P. QUILALA**
OIC-Director, Administrative Service

Recommending Approval:

(sgd) **JESUS ENRICO MOISES B. SALAZAR**
OIC Assistant Secretary for Human Resource,
Development and Administration

Approved by:

(sgd) **ROY. A CIMATU**
Secretary, DENR

II. OTHER REQUIREMENTS

1. Contractor to submit pictures/photos before, during and after conduct of Works.
2. All Materials to be used must be compliant with the Product Quality Standards set by the Bureau of Philippine Standards-DTI
3. All Materials to be used in the project must be presented for approval to DENR Authorized Representatives prior to its installation.
4. Bidder has no overdue deliveries or unperformed services intended for DENR.
5. Bidder did not participate as a consultant in the preparation of the design or technical specification of the WORKS subject of the bid.

III. REQUIREMENTS IF AWARDED THE CONTRACT

The Contractor shall submit the following within fourteen (14) calendar days after issuance of the Notice of Award:

A Detailed Program of Work for approval of DENR's Authorized Representative, which shall include among others:

- a) The order in which it intends to carry out the work including anticipated timing for each stage of Work.
- b) Periods for review of specific outputs and any other submissions and approvals.
- c) Sequence of timing for inspections and tests as specified in the contract documents.
- d) Number of names and personnel to be assigned for each stage of the work.
- e) List of Equipment required on site for each major stage of the work.
- f) Description of the quality control system to be utilized for the project.

BIDDER'S UNDERTAKING

I/We, the undersigned bidder, having examined the Bidding Documents including Bid Bulletins, as applicable, hereby BID to (supply/deliver/perform/comply) the above Terms of Reference

I/We undertake, if our bid is accepted, to deliver the goods/services in accordance with the terms and conditions contained in the bid documents, including the posting of the required performance security within ten (10) calendar days from receipt of the Notice of Award.

Until a formal contract/order confirmation is prepared and signed, this Bid is binding on us.

Name of Company (in print)

Signature of Company Authorized Representative

Name & Designation (in print)

Date

WORKING DRAWINGS

FLOOR PLAN LAYOUT

(For reference only)

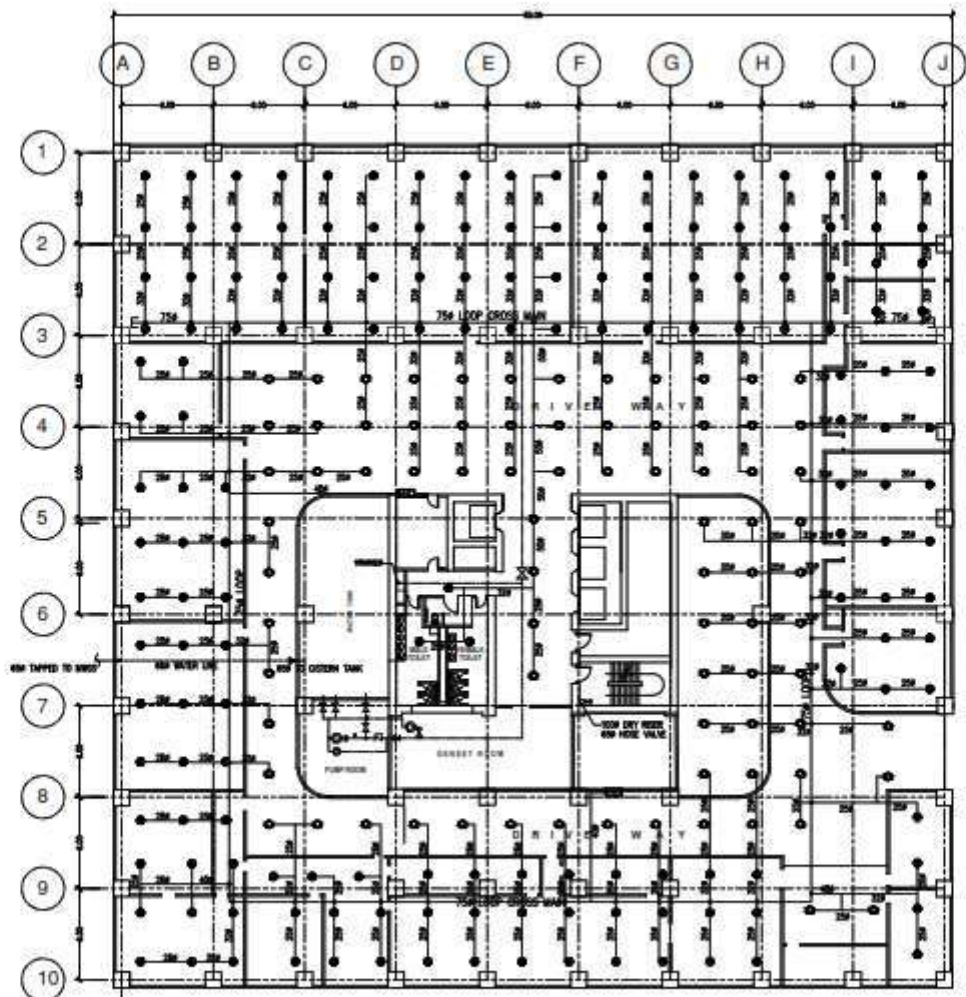

BASEMENT APIS		
Count	Notes	Layer
2	PH	APIS BRANCH LINE
81	Upright	APIS HEADS
101	PENDENT	APIS HEADS

BASEMENT FLOOR PLAN
SCALE 1:100 MTS.

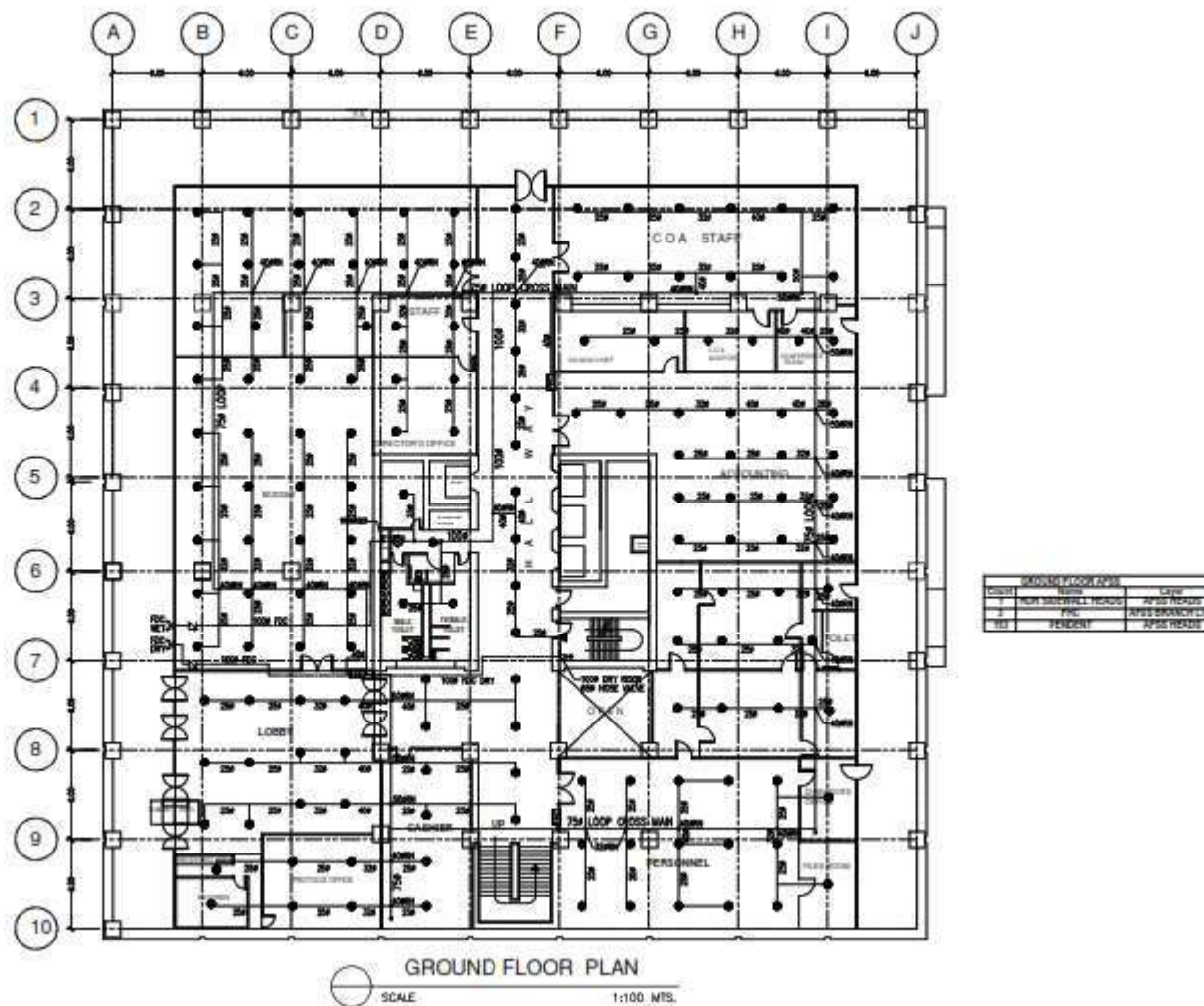

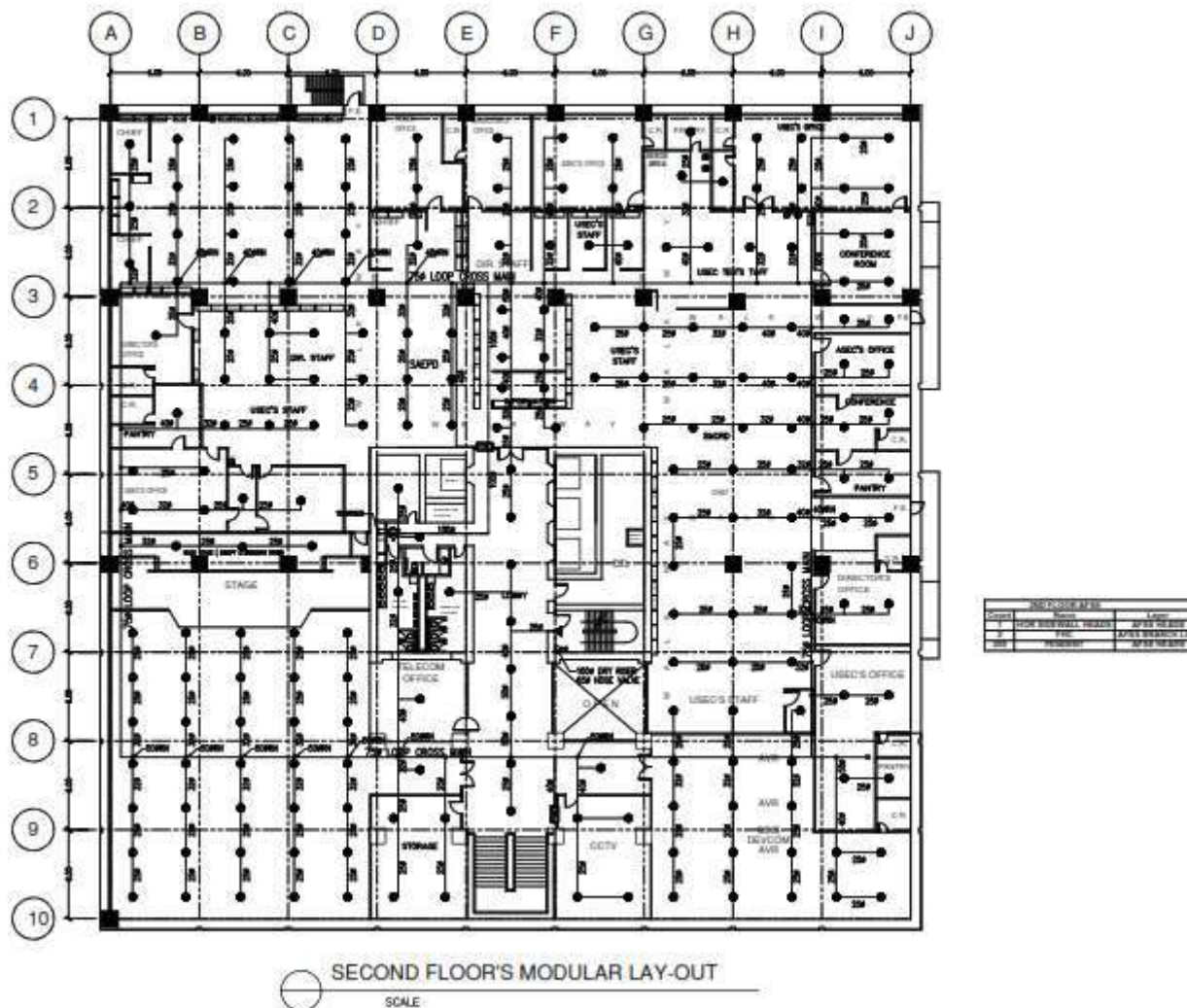

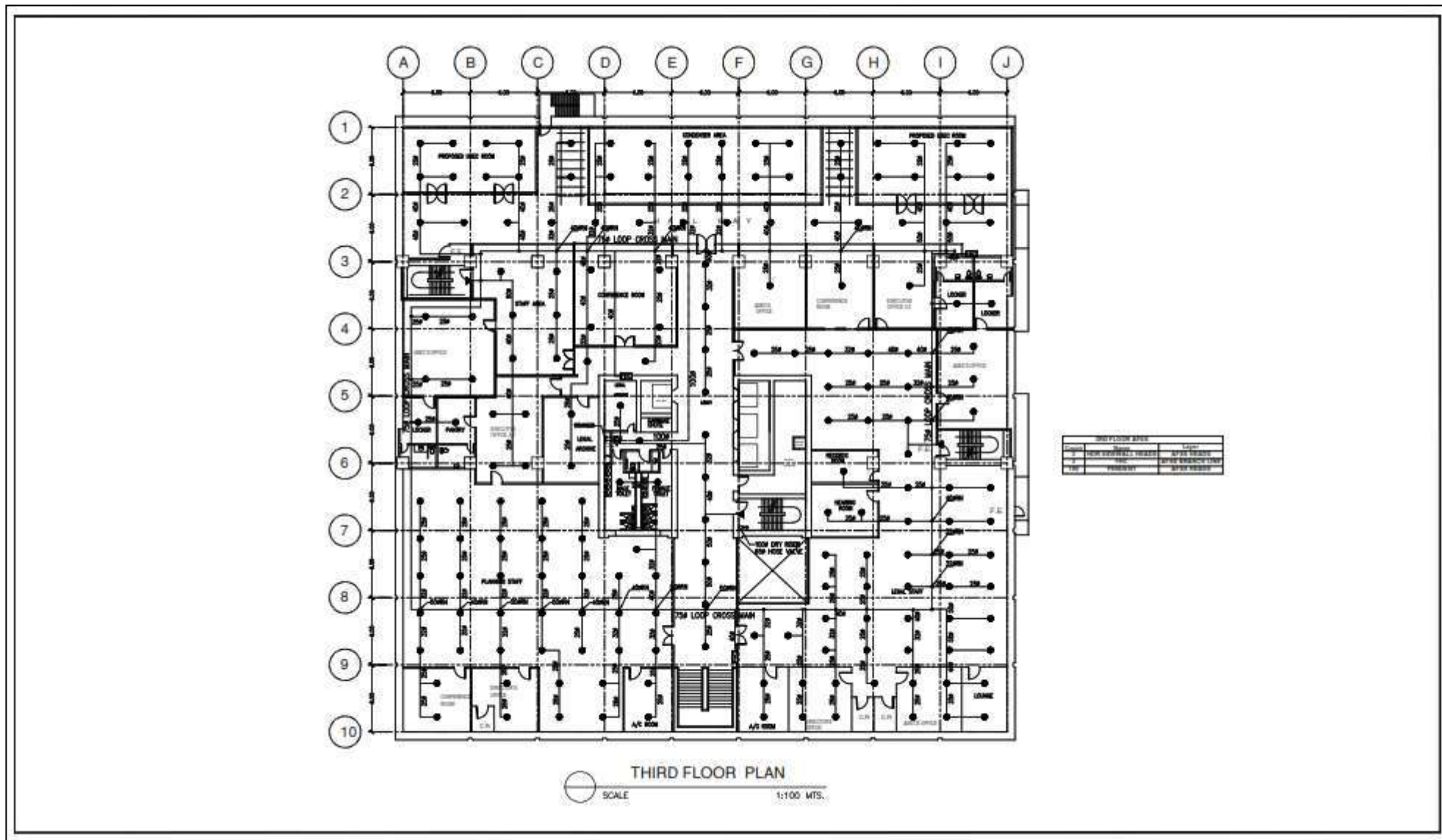

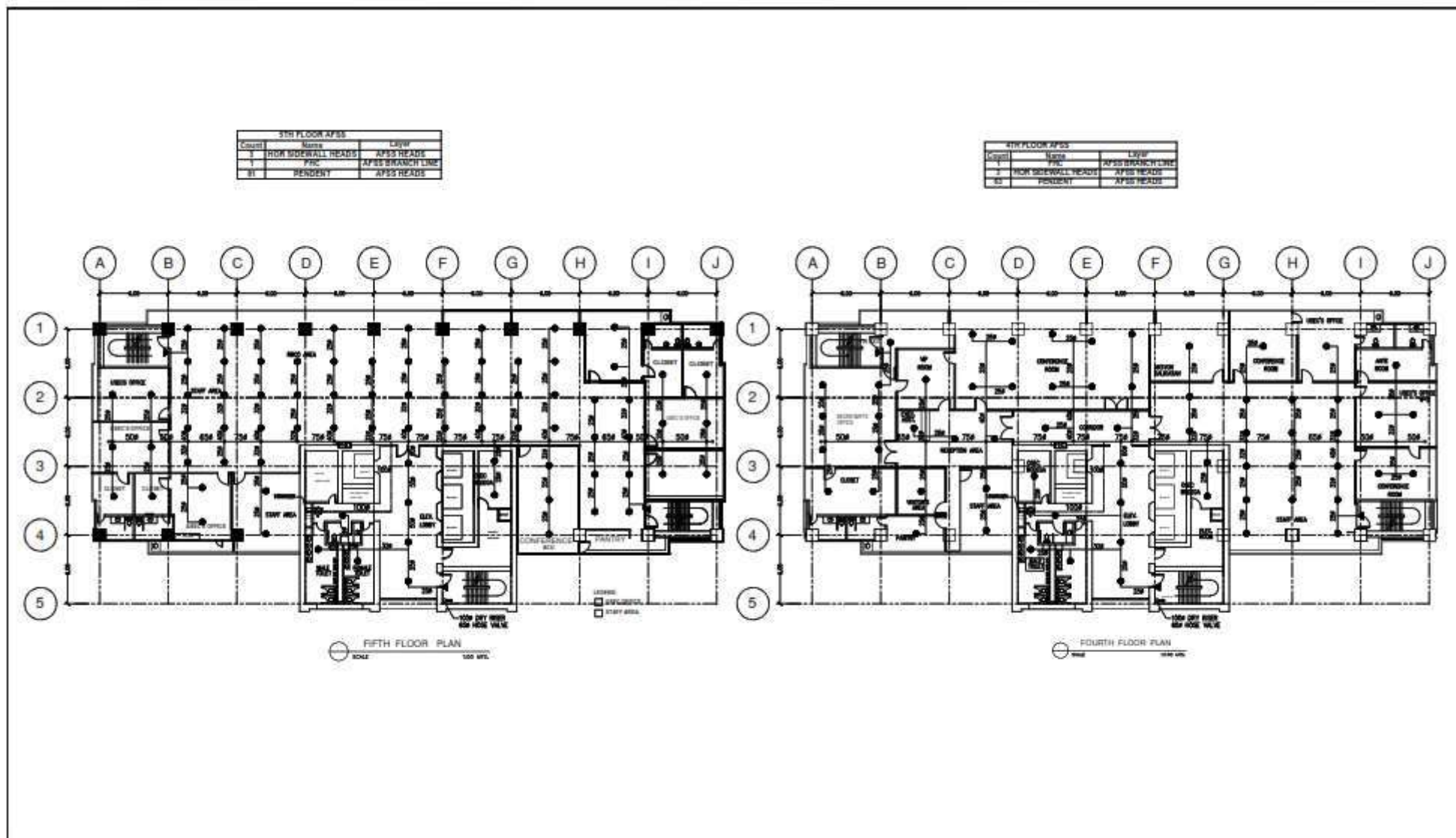

5TH FLOOR AFIS		
Count	Name	Qty
3	HOR SIDEWALL HEADS	AFIS HEADS
1	PIC	AFIS BRANCH LINE
81	PENDENT	AFIS HEADS

4TH FLOOR AFIS		
Count	Name	Qty
1	PIC	AFIS BRANCH LINE
3	HOR SIDEWALL HEADS	AFIS HEADS
83	PENDENT	AFIS HEADS

FIFTH FLOOR PLAN
SCALE 1/8" = 1'-0"

FOURTH FLOOR PLAN
SCALE 1/8" = 1'-0"

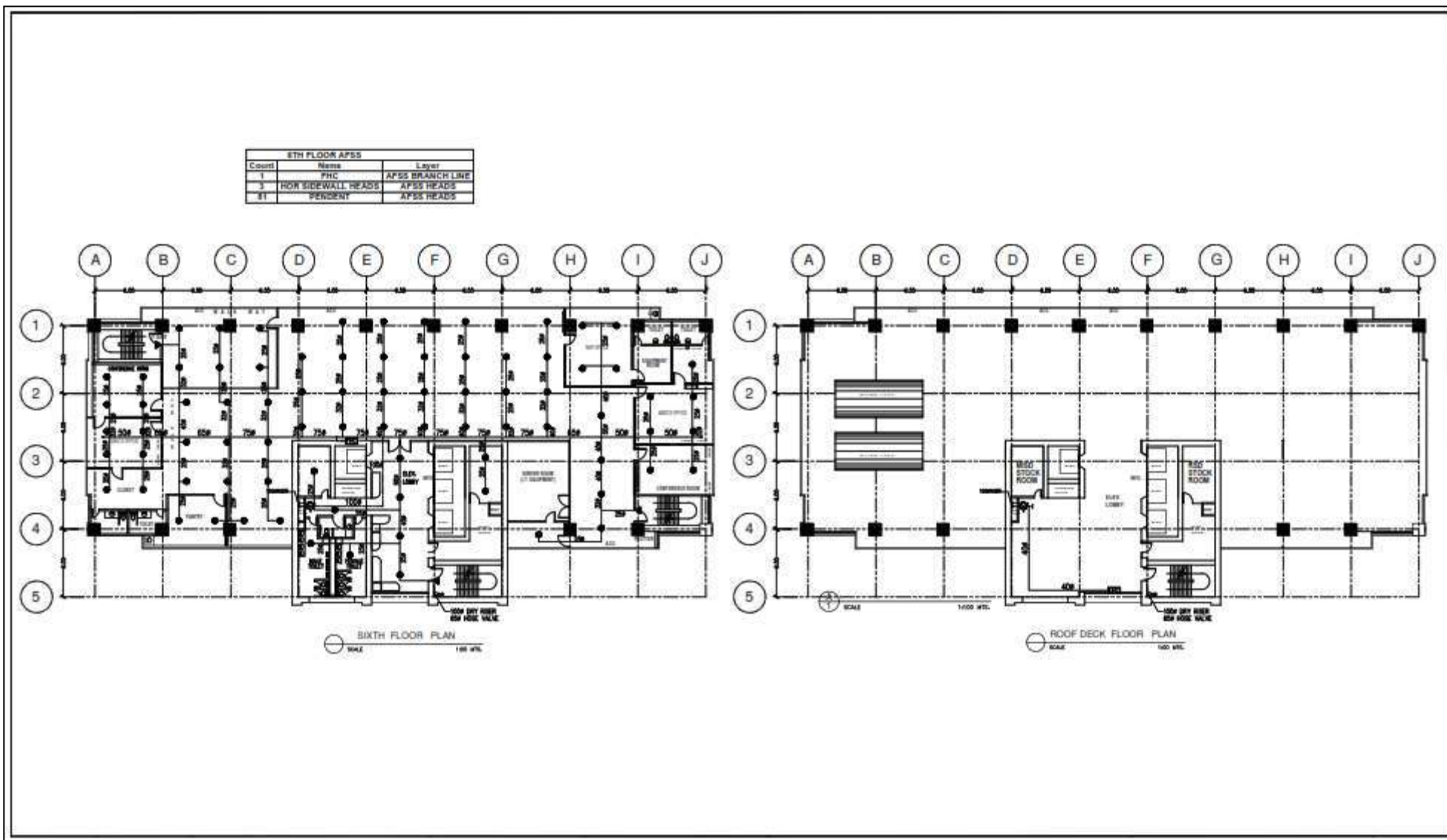

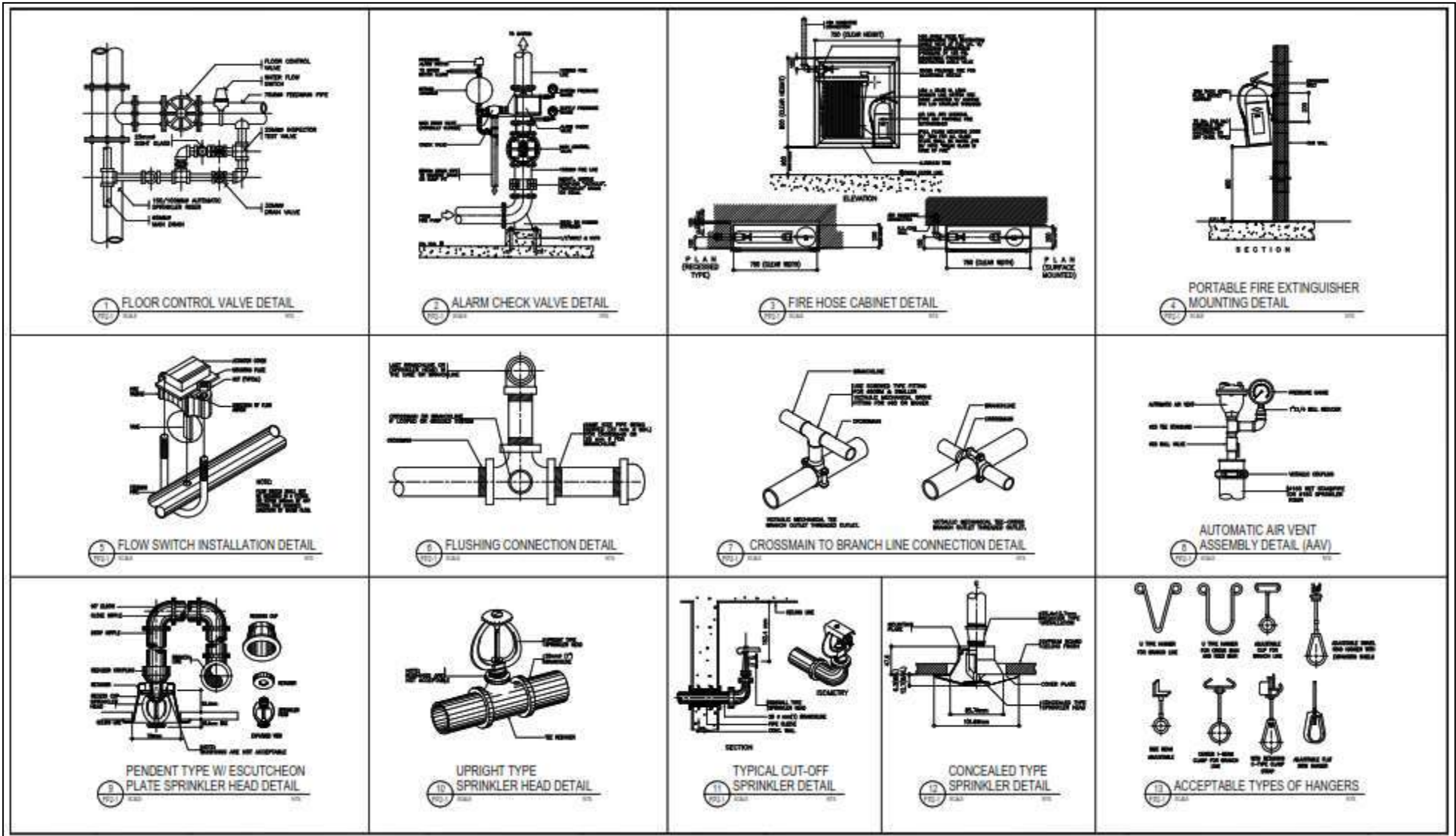

GENERAL NOTES:

- 01- ALL WORKS SHALL BE EXECUTED IN ACCORDANCE TO THE PROVISIONS OF THE FIRE CODE OF THE PHILIPPINES AND THE NATIONAL FIRE CODE BY NFPA.
- 02- THE WORK SHALL BE EXECUTED IN CLOSED COORDINATION WITH OTHER TRADES SO AS TO INSURE THE PROPER IMPLEMENTATION OF THIS PROJECT.
- 03- THE CONTRACTOR SHALL BE FULLY RESPONSIBLE FOR THE EXACT LOCATION AND DIMENSIONS OF ALL REQUIRED WALL AND FLOOR OPENINGS.
- 04- THE EXACT LOCATIONS OF ALL SPRINKLER HEADS SHALL BE COORDINATED WITH THE VICTORIA BLDG. REPRESENTATIVE AND SHALL BE SUBJECTED TO BOTH THE ARCHITECTS AND THE FIRE PROTECTION DESIGN ENGINEERS APPROVAL.
- 05- LOCATION OF DRAIN PIPES AND OF THE BUCK-UP SUPPLY LINES SHALL BE COORDINATED BY PLUMBING CONTRACTOR.
- 06- LOCATION AND MOUNTING OF FIRE HOSE CABINETS SHALL COORDINATED WITH THE ARCHITECTURAL FINISHES AND SHALL BE SUBJECTED TO BOTH THE ARCHITECTS AND FIRE PROTECTION DESIGN ENGINEERS APPROVAL.
- 07- SIZE OF THE RISER NIPPLES SHALL CONFORM TO PIPE SCHEDULES AS DELINEATED IN NFPA 13.
- 08- PIPE SUPPORT, HANGERS AND BRACINGS SHALL BE APPROVED TYPE AND SHALL BE INDEPENDENT FORM CEILINGS AND DUCT SUPPORT.
- 09- FP-1 AND JP-1 CIRCUIT BREAKERS AND STARTERS INCLUDING THE POWER WIRING AND CONDUITING TAPPING FROM MAIN CIRCUIT BREAKER AT FIRE PUMP ROOM SHALL BE SUPPLIED AND INSTALLED BY FIRE PROTECTION CONTRACTOR.
- 10- ALL WIRINGS TO MONITOR FLOW SWITCH IN THE FIRE ALARM PANEL SHALL BE SUPPLIED AND INSTALL BY FIRE PROTECTION CONTRACTOR. ROUGH-IN SHALL BE BY THE ELECTRICAL CONTRACTOR. WIRING SHALL BE TERMINATED TO THE DESIGNATED TERMINAL BLOCK IN THE ALARM PANEL.
- 11- SHOP DRAWING SHALL BE PREPARED FOR THE FIRE PUMP LAYOUT, PIPE HANGER AND OTHER INSTALLATION AS INDICATED IN THE SPECIFICATION.
- 12- THE CONTRACTOR SHALL PROVIDE AND INSTALL SOLID PORTABLE FIRE EXTINGUISHER IN FIRE HOSE CABINET. ALL PORTABLE FIRE EXTINGUISHERS SHALL BE LOCATED SO THAT ALL FIRE AT ANY POINT IN THE BUILDING CAN BE REACHED FROM ONE (1) EXTINGUISHER WITH A TRAVEL DISTANCE OF NOT MORE THAN 75 FT.
- 13- PROVIDE SECTIONALIZING AND FLOW SWITCHES FOR ALL CONNECTION TO RISER.
- 14- PIPE SHALL BE OF SCHEDULE 40 & SHALL CONFORM TO ASTM OR ANSI/ASTM A-120 OR API-5L. FOR PIPE SIZES LARGER THAN 50mm, THE FITTING SHALL ANSI B-8 FOR FLANGED BECS BUT WELDED TYPE, FITTING SIZE 50mm & SMALLER SHALL BE TREATED MALLEABLE IRON FITTINGS SHALL CONFORM TO ANSI B-16-3, CLASS 150.
- 15- PROVIDE UNION @ EACH THREADED OR WELDED CONNECTION TO EQUIPMENT & VALVES UP TO 50mm.
- 16- VALVES RATING SHALL MEET OR EXCEED THEIR RESPECTIVE SYSTEM OPERATING PRESSURE AND TEMPERATURE. ALL VALVE SHALL BE LINE SIZE UNLESS OTHERWISE SPECIFIED.
- 17- PIPE SHALL BE PAINTED W/ ONE (1) COAT PRIME & TWO (2) COATS FINAL.
- 18- SPACING OF SPRINKLER & BRANCH LINE SHALL CONFORM TO THE DRAWINGS.
- 19- A MINIMUM OF 50mm CLEARANCE SHALL BE PROVIDED AROUND PIPING EXTENDED THROUGH WALL, FLOORS, PLATFORMS & FOUNDATION, INCLUDING DRAINS & OTHER AUXILIARY PIPING.
- 20- JOINT COMPOUND OR TAPE SHALL BE APPLIED TO THE THREADS OF THE PIPE & NOT IN FITTING.
- 21- PIPE HANGER SHALL BE IN SUCH THAT COULD SUPPORT FIVE TIMES THE HEIGHT OF THE WATER FILLED PIPE PLUS 11400 @ EACH POINT OF PIPING SUPPORT.
- 22- MAXIMUM DISTANCE BETWEEN HANGERS SHALL NOT EXCEED 3.6M (12FT.) FOR 25mm OR 4.27(15FT.) FOR 38mm & LARGER DIAMETER

LEGEND & SYMBOLS:

SYMBOLS	DESCRIPTION
	END CAP
	PENDENT TYPE SPRINKLER HEADS (OPTIONAL FINISH W/ ESCUTCHION PLATE)
	UPRIGHT TYPE SPRINKLER HEADS
	COMBINATION TYPE SPRINKLER HEADS (PENDENT & UPRIGHT) OR ABOVE & BELOW CEILING
	SIDEWALL TYPE SPRINKLER HEADS, EXTENDED COVERAGE TYPE
	CHECK VALVE, FLANGED
	OS & Y GATE VALVE, FLANGED
	CHECK VALVE, SCREWED
	OS & Y GATE VALVE, SCREWED
	PRESSURE RELIEF VALVE WITH ENCLOSED WASTE/COOL DISCHARGE TO DRAIN
	WATER FLOW DETECTOR
	OS & Y GATE VALVE, WITH SUPERVISORY SWITCH
	ALARMED CHECK VALVE ASSEMBLY
	SPRINKLER RISER
	SIGHT GLASS
	DRAIN VALVE
	FIRE DEPARTMENT CONNECTION 65 x 65 x 100
	HANGER SUPPORT
	LATERAL SWAY BRACE
	LONGITUDINAL SWAY BRACE
	FOUR WAY RISER BRACE
	RISER NIPPLE
	FLEXIBLE CONNECTOR
	REDUCER (ECCENTRIC)
	REDUCER (CONCENTRIC)
	FLOW METER DEVICE
	PORTABLE FIRE EXTINGUISHER -- CO2 TYPE
	PORTABLE FIRE EXTINGUISHER -- CO2 TYPE
	AUTOMATIC FIRE SPRINKLER SYSTEM
	FLOOR CONTROL VALVE
	FIRE HOSE CABINET

MATERIAL SPECIFICATIONS:

- PIPES & FITTINGS:** FIRE LINES ARE BLACK IRON/STEEL PIPE SCHEDULE 40, STANDARD CONFORMING TO ASTM A-120-1980 "AFO" OR APPROVED EQUAL.
- VALVES:** GATE VALVE ARE OUTSIDE AND YOKE (OS&Y) TO ASTM B-62 CHECK VALVES AND GLOBE VALVES TO ASTM B-62
- SPRINKLER HEADS:** ALL SPRINKLER HEADS (PENDENT, UPRIGHT, SIDEWALL & CONCEALED) ARE RATED 165°F EXCEPT ON KITCHEN AND MACHINE ROOM ARE 212°F.

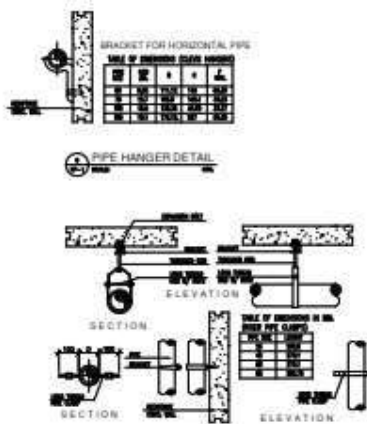

VICINITY MAPS

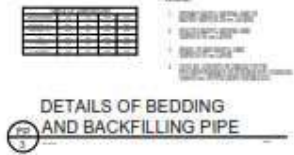
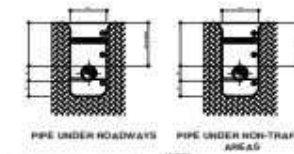

SCHEDULE OF EQUIPMENT

DESIGNATION	QUANTITY	TYPE	DRIVE	PUMP CHARACTERISTICS			MOTOR DATA			
				CAPACITY (GPM)	HEAD (PSI)	SPEED (RPM)	RATING (HP)	VOLTAGE	PHASE	CYCLE
FP - 1	1	HORIZONTAL	ELECTRIC	500	120	3600	60	460	3ø	60 Hz
FP - 2	1	HORIZONTAL	DIESEL	500	120	3000				
JP - 1	1	HORIZONTAL	ELECTRIC	50	130	3450	7.5	460	3ø	60 Hz

SCHEDULE OF PIPE SLEEVE

PIPE SIZE	NOMINAL SIZE						
	25	32	40	50	65	80	100
SLEEVE SIZE	50	50	45	100	125	125	200

PIPE SIZE CONVERSION TABLE

PIPE SIZE	NOMINAL SIZE						
	25	32	40	50	65	80	100
MM (DIAMETER)	25	32	40	50	65	80	100
IN. (DIAMETER)	1"	1 1/8"	1 1/2"	2"	2 1/2"	3"	4"

SCHEDULE OF EQUIPMENT

DESIGNATION	QUANTITY	TYPE	DRIVE	PUMP CHARACTERISTICS				MOTOR DATA		
				CAPACITY (GPM)	HEAD (PSI)	SPEED (RPM)	RATING (HP)	VOLTAGE	PHASE	CYCLE
FP - 1	1	HORIZONTAL	ELECTRIC	500	120	3600	80	480	3ø	60 Hz
FP - 2	1	HORIZONTAL	DIESEL	500	120	3000				
JP - 1	1	HORIZONTAL	ELECTRIC	50	130	3450	7.5	480	3ø	60 Hz

MATERIAL LIST - PUMP ROOM		
ITEM NO.	DESCRIPTION	QTY
1	100% DIESEL ENGINE/GENERATOR SET	1
2	ELECTRIC DRIVE/GENERATOR SET	1
3	ELECTRIC DRIVE/GENERATOR SET	1
4	100% DIESEL ENGINE	1
5	100% DIESEL ENGINE	1
6	100% DIESEL ENGINE	1
7	100% DIESEL ENGINE	1
8	100% DIESEL ENGINE	1
9	100% DIESEL ENGINE	1
10	100% DIESEL ENGINE	1
11	100% DIESEL ENGINE	1
12	100% DIESEL ENGINE	1
13	100% DIESEL ENGINE	1
14	100% DIESEL ENGINE	1
15	100% DIESEL ENGINE	1
16	100% DIESEL ENGINE	1
17	100% DIESEL ENGINE	1
18	100% DIESEL ENGINE	1
19	100% DIESEL ENGINE	1
20	100% DIESEL ENGINE	1

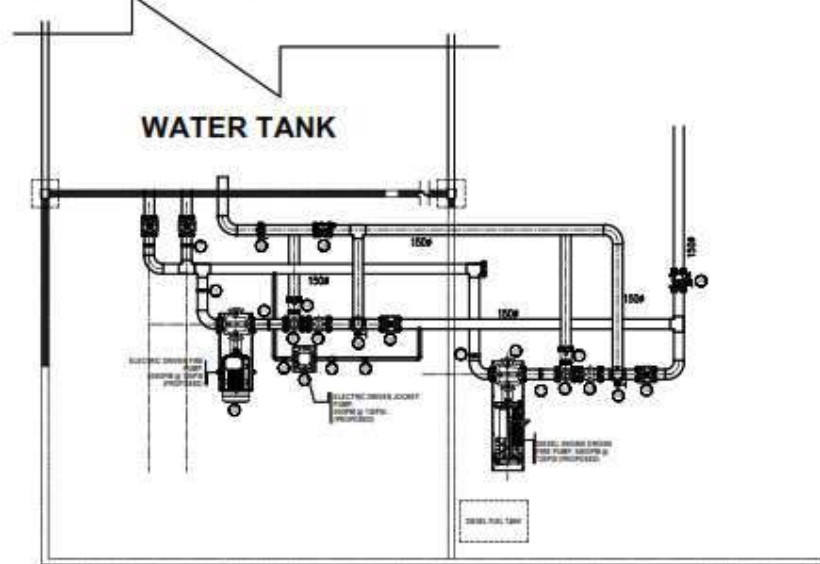

○ PROP. PUMP LAYOUT @ BASEMENT
SCALE N T S

LEGEND:

- - FLEXIBLE COUPLING
- - PRESSURE GAUGE
- - FIRE PUMP, 1000GPM @ 150PSI (TYPICAL OR TWO)
- - JOCKEY PUMP, 50GPM @ 150PSI
- - PRESSURE RELIEF VALVE
- - CHECK VALVE
- - OS & Y GATE VALVE
- - FLOW METER
- - BUTTERFLY VALVE
- - HOSE VALVE

NOTES:

- ALL ALARM CHECK VALVE, FLOW SWITCH AND GAGE VALVES (OS&Y OR BUTTERFLY VALVES) SHALL BE INTERLOCKED TO THE FIRE ALARM CONTROL PANELS (REFER TO ELECTRICAL FIRE ALARM SYSTEM PLANS).
- ALL HOSE VALVES AT FIRE PUMP ROOM SHALL BE OS&Y TYPE WITH MONITOR SWITCH AND TO BE INTERLOCKED WITH FIRE ALARM SYSTEM BY THE SPRINKLER CONTRACTOR.

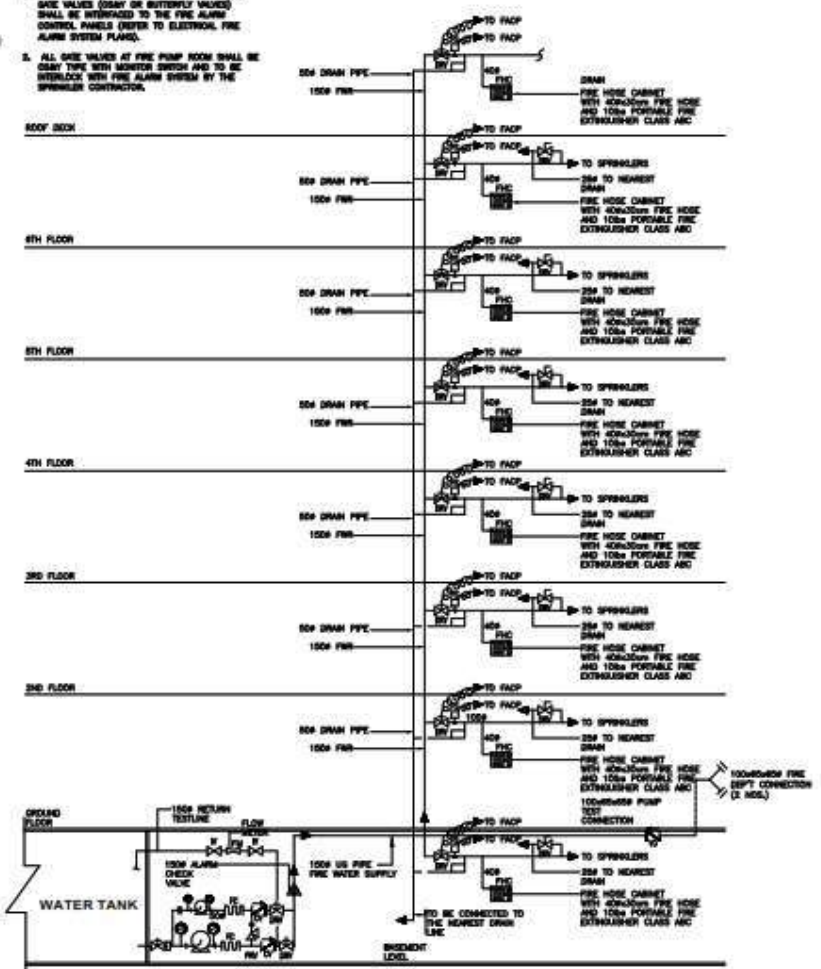

○ SCHEMATIC DIAGRAM
SCALE N T S

DENR BIDS AND AWARDS COMMITTEE
REVISED CHECKLIST OF REQUIREMENTS FOR BIDDERS

Name of Company: _____
Project: REPLACEMENT OF FIRE SPRINKLER SYSTEM AND INSTALLATION OF JOCKEY PUMP OF THE DEPARTMENT OF ENVIRONMENT AND NATURAL RESOURCES-CENTRAL OFFICE (DENR-CO)
Bid Ref. No. Bid Ref. No.DENR-CO-2020-003 Rebid
APPROVED BUDGET FOR THE CONTRACT: P25,000,000.00

Ref. No.	Particulars	
----------	-------------	--

ENVELOPE 1: ELIGIBILITY AND TECHNICAL DOCUMENTS

In accordance with Clause 19.4 of the Instructions to Bidders, the bid, except for the unamended printed literature, shall be signed, and each and every page thereof shall be initialed, by the duly authorized representative/s of the Bidder.

12.1		(a) ELIGIBILITY DOCUMENTS	
(a)		CLASS "A" DOCUMENTS	
		<u>(a.1.) LEGAL DOCUMENTS</u>	
	(i)	<p>Sworn statement in accordance with Section 25.3 of the IRR of RA 9184 and using the prescribed form attached as Annex I with attached <u>Proof of Authority of the bidder's authorized representative/s</u>:</p> <p>i. FOR SOLE PROPRIETORSHIP (IF OWNER OPTS TO APPOINT A REPRESENTATIVE):Notarized or unnotarized Special Power of Attorney</p> <p>ii. FOR CORPORATIONS, COOPERATIVE OR THE MEMBERS OF THE JOINT VENTURE: Notarized or unnotarized Secretary's Certificate evidencing the authority of the designated representative/s.</p> <p>Notes: 1) Should there be more than one (1) appointed authorized representatives, use the word "<u>any of the following</u>" or "<u>OR</u>", otherwise, all authorized representatives must sign/initial the bid submission.</p> <p><u>2) Unnotarized documents shall be accepted pursuant to GPPB Resolution No. 09-2020 dated 07 May 2020.</u></p> <p>IN THE CASE OF UNINCORPORATED JOINT VENTURE: Each member shall submit a separate Special Power of Attorney and/or Secretary's Certificate evidencing the authority of the designated representative/s.</p>	
	(ii)	<p>Valid and current Certificate of PhilGEPS Registration (Platinum Membership) issued to bidder; <i>[Note: The valid and current Certificate of Registration (Platinum Membership) shall reflect the updated eligibility documents. Should the Annex A of said Certificate reflects not updated documents, the bidder shall submit, together with the certificate certified true copies of the updated documents]</i></p> <p><u>OR</u></p> <p>The following Class "A" eligibility documents:</p> <p>a) Registration certificate from SEC, Department of Trade and Industry (DTI) for sole proprietorship, or CDA for cooperatives;</p> <p>b) Copy of any of the following documents issued to bidder by the city or municipality where the principal place of business of the bidder is located or the equivalent document for Exclusive Economic Zones or Areas :</p>	

	<p>i. Business/Mayor's Permit for 2020.</p> <p>ii. Application for Business/Mayor's Permit with attached Official Receipt (OR) of payment of Licensing and Regulatory fees and 2019 Business/Mayor's Permit.</p> <p><u>Note: Expired Business/Mayor's permit with Official Receipt of renewal application shall be accepted. Valid and current Business/Mayor's permit is subject for submission after award of contract but before payment, pursuant to GPPB Resolution No. 09-2020 dated 07 May 2020.</u></p> <p>c) Current and valid Tax Clearance per E.O. 398, series of 2005, as finally reviewed and approved by the Bureau of Internal Revenue (BIR);</p> <p>d) Audited Financial Statements (AFS) for CY 2019 with stamped "received" by the Bureau of Internal Revenue (BIR) or its duly accredited and authorized institutions dated CY 2020;</p>	
<u>(a.2.) TECHNICAL DOCUMENTS</u>		
(iii)	Statement of all its ongoing government and private contracts, including contracts awarded but not yet started, if any, whether similar or not similar in nature and complexity to the contract to be bid (per Annex II);	
(iv)	<p>Statement of the Bidder's Single Largest Completed Contract (SLCC) of similar nature equivalent to at least fifty (50%) of the total ABC (per Annex II-A)</p> <p><i>Similar Contracts shall refer to contracts involving installation and replacement of Fire Sprinkler and Jockey Pump of buildings.</i></p> <p><u>Any of the following documents must be submitted/attached corresponding to listed completed largest contracts per Annex II-A:</u></p> <p>(a) Constructor's Performance Evaluation System (CPES) with a Final Rating of at least SATISFACTORY; or</p> <p>(b) Owner's Certificate of Acceptance, or</p> <p>(c) Owner's Certificate of Completion</p>	
(iv)	Valid and current Philippine Contractors Accreditation Board (PCAB) License with Classification/Category in General Building/General Engineering with License Category C or D and Size Range of Small B (SP-ME) and (SP-FP) . The PCAB license must indicate "PCAB registered contractor for Government Projects."	
<u>(a.3.) FINANCIAL DOCUMENTS</u>		
(v)	<p>Net Financial Contracting Capacity (NFCC) computation, in accordance with ITB Clause 5.5, (per Annex III).</p> <p>The NFCC computation must be equal to the ABC of this project. The detailed computation using the required formula must be provided.</p> <p><u>In case of Joint Venture, the partner responsible to submit the NFCC shall likewise submit the Statement of all its ongoing contracts and the Latest Audited Financial Statements.</u></p>	

Class “B” Document: (For Joint Venture)

(i) Valid Joint Venture Agreement (JVA)

The JVA must specify which Partner/Company of the JV shall be designated as Authorized Representative. It must also clearly state the Name of the Officer/s designated as the Authorized Representative/s of the Joint Venture.

(ii) Each partner of a JV shall likewise submit the following:

- a) Valid and current Certificate of PhilGEPS Registration
- b) Valid and current PCAB License.

(iii) Submission of the following by any of the JV partners constitute compliance:

- a) Statement of All Ongoing Contracts whether similar or not similar in nature (Annex II)
- b) Statement of Single Largest Completed Contract (Annex II-A)
- c) Duly signed NFCC

(iv) Entities forming themselves into a Joint Venture shall likewise submit an additional PCAB license to act in the capacity of such joint venture.

(b) TECHNICAL DOCUMENTS

(i)

Original Bid Security must be issued in favor of the **DEPARTMENT OF ENVIRONMENT AND NATURAL RESOURCES (DENR)** (must be valid for at least 120 calendar days from the date of bid opening); any one of the following forms:

Project ABC (₱)	Bid Security: Cash, Cashier’s/ Manager’s Check, Bank Draft / Guarantee, Irrevocable Letter of Credit (2%) (₱)	Bid Security: Surety Bond (5%) (₱)	Bid Securing Declaration
25,000,000.00	500,000.00	1,250,000.00	No required Amount

- 1. Bid Securing Declaration per **Annex IV**;
- 2. The Cashier’s/Manager’s Check shall be issued by a Local, Universal or Commercial Bank
- 3. The Bank Draft/Guarantee or Irrevocable Letter of Credit shall be issued by a Local Universal or Commercial Bank; or
- 4. Should bidder opt to submit a Surety Bond as Bid Security, the surety bond must be callable on demand and must be issued by a surety or insurance company duly certified by the Insurance Commission as authorized to issue such bond. Together with the surety bond, a certification from Insurance Commission must be submitted by the bidder which must state that the surety or insurance company is specifically authorized to issue surety bonds.
- 5. For submission of Bank Draft/Guarantee or Irrevocable Letter of Credit or Surety Bond, the following must be stated/specified in the Bid Security pursuant to Section III, ITB Clause 18.5, to wit:

The following are the grounds for forfeiture of Bid Security

▪ **IF A BIDDER:**

- a) Withdraws its bid during the period of bid validity.
- b) Does not accept the correction of errors pursuant to Section 32.2.1 of the IRR of RA 9184.
- c) Fails to submit the Post Qualification requirements within the prescribed period or a finding against their veracity thereof.
- d) Submission of eligibility requirements containing false information or falsified documents.
- e) Submission of bids that contain false information or falsified documents, or the concealment of such information in the bids in order to influence the outcome of eligibility screening or any other stage of the public bidding.
- f) Allowing the use of one’s name, or using the name of another for purposes of public bidding.
- g) Withdrawal of a bid, or refusal to accept an award, or enter into contract with the Government without justifiable cause, after the Bidder had been adjudged as having submitted the Lowest Calculated and Responsive Bid.
- h) Refusal or failure to post the required performance security within the prescribed time.

	<ul style="list-style-type: none"> i) Refusal to clarify or validate in writing its bid during post-qualification within a period of seven (7) calendar days from receipt of the request for clarification. j) Any documented unsolicited attempt by a bidder to unduly influence the outcome of the bidding in his favor. k) Failure of the potential joint venture partners to enter into the joint venture after the bid is declared as successful. l) All other acts that tend to defeat the purpose of the competitive bidding, such as habitually withdrawing from bidding, submitting late Bids or patently insufficient bid, for at least three (3) times within a year, except for valid reasons. <p>▪ IF THE SUCCESSFUL BIDDER:</p> <ul style="list-style-type: none"> (i) fails to sign the contract in accordance with Section 40 of the Revised IRR of RA 9184; or (ii) fails to furnish performance security in accordance with Section 40 of the Revised IRR of RA 9184. <p><u>Note: Duly notarized or Unnotarized Bid Securing Declaration shall be accepted pursuant to GPPB Resolution No. 09-2020 dated 07 May 2020.</u></p>
--	---

	<p>Conformity with Project Specifications as specified in the Section VI (Terms of Reference as of 25 June 2020 with Working Drawings) of the Supplemental/Bid Bulletin No. 1 attached with the following:</p> <ol style="list-style-type: none"> 1. Organizational Chart for the contract to bid; 2. List of contractor's Key Personnel to be assigned to the contract to be bid, with their complete qualifications and experience data and other requirements as specified below. Required Key Personnel are as follows: <table border="1" style="width: 100%; border-collapse: collapse;"> <thead> <tr> <th style="text-align: center;">Key Personnel</th> <th style="text-align: center;">Experience</th> <th style="text-align: center;">Documentary Requirements</th> </tr> </thead> <tbody> <tr> <td>At least one (1) Mechanical Engineer</td> <td>Five (5) years</td> <td> <ul style="list-style-type: none"> • Curriculum Vitae • Valid and current Professional Identification Card issued by Professional Regulatory Commission (PRC) </td> </tr> <tr> <td>At least one (1) Master Plumber</td> <td>Five (5) years</td> <td> <ul style="list-style-type: none"> • Curriculum Vitae • Valid and current Professional Identification Card issued by Professional Regulatory Commission (PRC) </td> </tr> <tr> <td>At least four (4) Welders</td> <td>Five (5) years</td> <td> <ul style="list-style-type: none"> • NC II Certified by the Technical Education and Skills Development Authority </td> </tr> </tbody> </table> <ol style="list-style-type: none"> 3. List of contractor's equipment units, which are owned, leased, and/or under purchase agreements, supported by certification of availability of equipment from the equipment lessor/vendor for the duration of the project. 	Key Personnel	Experience	Documentary Requirements	At least one (1) Mechanical Engineer	Five (5) years	<ul style="list-style-type: none"> • Curriculum Vitae • Valid and current Professional Identification Card issued by Professional Regulatory Commission (PRC) 	At least one (1) Master Plumber	Five (5) years	<ul style="list-style-type: none"> • Curriculum Vitae • Valid and current Professional Identification Card issued by Professional Regulatory Commission (PRC) 	At least four (4) Welders	Five (5) years	<ul style="list-style-type: none"> • NC II Certified by the Technical Education and Skills Development Authority
Key Personnel	Experience	Documentary Requirements											
At least one (1) Mechanical Engineer	Five (5) years	<ul style="list-style-type: none"> • Curriculum Vitae • Valid and current Professional Identification Card issued by Professional Regulatory Commission (PRC) 											
At least one (1) Master Plumber	Five (5) years	<ul style="list-style-type: none"> • Curriculum Vitae • Valid and current Professional Identification Card issued by Professional Regulatory Commission (PRC) 											
At least four (4) Welders	Five (5) years	<ul style="list-style-type: none"> • NC II Certified by the Technical Education and Skills Development Authority 											

ENVELOPE 2: FINANCIAL DOCUMENTS

13.1	<p>Completed and signed Financial Bid Form. Bidder must submit the following:</p> <ol style="list-style-type: none"> 1. Bid Form per Annex V 2. Bid Prices in the Bill of Quantities per Section VIII 3. Detailed estimates, including a summary sheet indicating the unit prices of construction materials, labor rates, and equipment rentals used in coming up with the Bid 4. Cash flow by quarter or payment schedule 5. Digital copy store in Universal Serial Bus (USB) flash drive in Excel File. <p>The ABC is inclusive of VAT. Any proposal with a financial component exceeding the ABC shall not be accepted.</p>
-------------	---

Note: In case of inconsistency between the Checklist of Requirements for Bidders and the provisions in the Instruction to Bidders/Bid Data Sheet, the Instruction to Bidders/Bid Data Sheet shall prevail.